

SERIAL #:

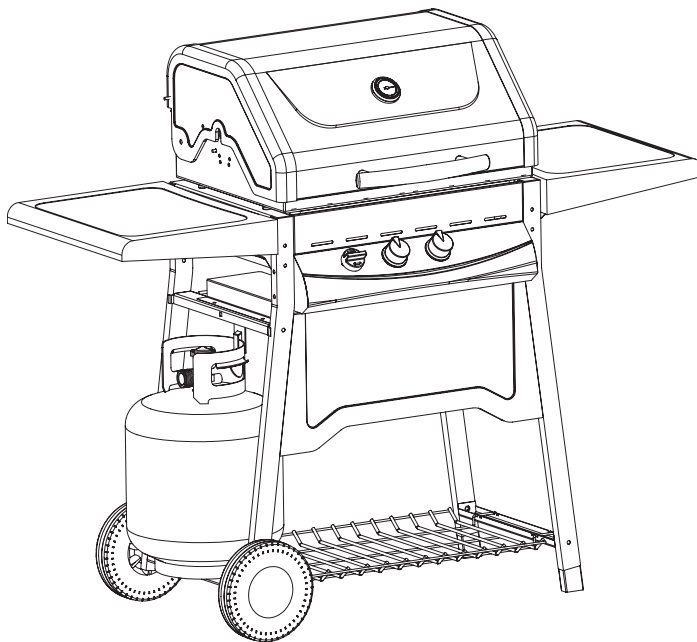

Propane Barbecue

SAFE USE, CARE AND ASSEMBLY MANUAL



FOR YOUR SAFETY

If You Smell Gas

1. Immediately turn off the flow of gas to the unit.
2. Extinguish any open flame.
3. Open the lid of the unit.
4. If the odour does not stop quickly, immediately call your gas supplier or Fire Department for assistance.

FOR YOUR SAFETY

1. Do not store or use gasoline or other flammable vapours and liquids in the vicinity of this or other appliance.
2. An LP Gas cylinder not connected for use shall not be stored in the vicinity of this or other appliance.

WARNING

Failure to follow all of the manufacturer's instructions could result in hazardous fires, explosions, property damage, or serious personal injury or even death.

WARNING

Follow all leak check procedures carefully prior to operation of barbecue, even if barbecue was stored assembled. Do not try to light this barbecue without reading the Lighting Instructions section of this manual.

**THIS BARBECUE IS FOR
OUTDOOR USE ONLY**

3-YEAR LIMITED WARRANTY

85-1261-0 (PROPANE)
(G30101)

Read and save this manual for future reference.
If pre-assembled, leave this manual with
unit for consumer's future reference.

For product inquiries, parts, warranty
and troubleshooting support, please call
1-877-707-5463

TABLE OF CONTENTS

Warranty ii

Installation 1

Additional Warnings 1

L.P. Gas Cylinder, 1
Transportation and Storage of
Cylinder, Filling the Cylinder

Hose and Regulator 3

Leak Testing 4

Prior to Using 4

Lighting the Grill 6

General Grilling Tips 8

Barbecue Cooking 9
Methods

Cooking Time Chart 10

Cleaning and Maintenance, . . 12
Storage

Troubleshooting Guide. 13

Parts List and 14
Parts Diagram (Propane)

Assembly Instructions 16



WARRANTY

3 Year Limited Warranty

This MasterChef® Gourmet Barbecue carries a three year limited warranty against defects in manufacturing workmanship. This Limited Warranty is nontransferable and becomes void if used for commercial or rental purposes. This warranty applies only when grill is used in Canada. The bill of sale or a copy will be required together with the serial number and model number when making any warranty claims from Trileaf Distribution. Trileaf Distribution reserves the right to have its representatives inspect any product or part prior to honouring any warranty claim. Trileaf Distribution shall not be liable for any transportation charges, or labour cost. This warranty is for replacement of defective parts only. The Manufacturer will not be responsible for incidental or consequential damages or any labour cost. Inability to provide proof of purchase, or if warranty coverage has expired, any request for parts will be subject to parts, shipping and handling fees.

This limited warranty does not cover damage due to chipping and scratching of porcelain or painted surfaces, nor does it cover corrosion or discolouration due to misuse, lack of maintenance, grease fires, hostile environments, accidents, alterations, abuse or neglect, improper installation and failure to read and/or abide by any product warnings. This limited warranty does not cover any damage sustained during removal or storage of this Barbecue. This limited warranty does not cover any scratches or dents, corrosion or discolouring caused by heat, abrasive or chemical cleaners. Parts installed from other manufactures will nullify this warranty.

3 Year Limited Warranty

Should deterioration of parts occur to the degree of non-performance within the duration of the warranty coverage a replacement part will be provided. The following functional parts are included under this warranty: Burners, cooking grates, flame tamers, ignitor, manifold assembly, and carry-over assembly.

1 Year Limited Warranty

For one year from the date of original retail purchase Trileaf Distributions will replace any grill part that fails or is found to be defective in manufacturing workmanship under normal household use, during the limited warranty period. Unless otherwise noted all components are covered for a period of one year.

IMPORTANT: Should this product become defective within the stated warranty period, DO NOT RETURN TO STORE. PLEASE CALL 1-877-707-5463. Have your Proof of purchase, serial number and model number available so that the customer support agent can be of assistance.

Purchaser: By accepting delivery of this Barbecue the purchaser, hereby accepts the foregoing and expressly waives any other remedy and damages, direct, indirect, and consequential.

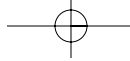

INSTALLATION

The installation of this appliance must be in accordance with all local codes, or in the absence of local codes:

- Canadian installation must conform to the current national standards, which at this time are CAN/CGA-B149.1/2-Natural Gas/Propane installation code.

ADDITIONAL WARNINGS

Minimum clearance to adjacent combustible materials:

- 76 cm (30") from furthest protruding edge on side of barbecue.
- 76 cm (30") from furthest protruding edge on back of barbecue.

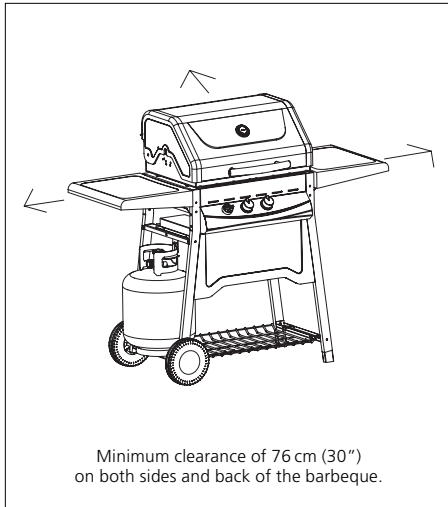

Drawing A

See Drawing A

- Always keep the area around this barbecue clean and clear of any and all combustible materials such as gasoline or other inflammable liquids, paper or oily rags.
- **Do not** operate this barbecue under any overhanging or unprotected construction.
- Remember this barbecue is for **outdoor use only** and is **not** for use on any boat or recreational vehicle.
- Use this barbecue outdoors in a well-ventilated area and at least 3 m (10') from any dwelling or other building.
- **Do not** use in garages, or any other enclosed area.
- **Do not** leave your barbecue unattended while in operation.
- **Do not** obstruct the flow of combustion and ventilation air to the barbecue.
- **Do not** use while under the influence of drugs or alcohol.
- **Do not** store any spare L.P. (propane) cylinders, full or empty, under or near your barbecue.
- **Do not** allow children or pets to play anywhere near the barbecue.

L.P. GAS CYLINDER

Self-contained Propane Gas System

The self-contained (propane) gas system barbecue is designed to be used with only a 9.1 kg (20 lb) propane cylinder equipped with a type-1 cylinder valve. This barbecue **cannot** be connected to an existing #510 P.O.L. type valve cylinder (which has left-handed threads).

Do not connect to a propane gas cylinder exceeding 9.1kg capacity or use a cylinder with any other type of cylinder valve connection device.

The Type-1 valve can easily be recognized by the large external thread on the outside of the valve. Older existing valves **do not** have this outer external thread. Any attempt to connect a regulator to any connector other than the mating Type-1 connector (which comes with a large, black coupling nut such as the #510 P.O.L.) could result in fires, injuries or property damage, and could reduce the effectiveness of the important safety features built into the Type-1 system. Also connecting the #510 P.O.L. fitting to the cylinder will negate the flow control and the temperature shut-off features built into the new Type-1 connection system.

- The cylinder should not exceed 472 mm (18 1/2") in height and 317 mm (12 1/2") in diameter.

When purchasing a cylinder for your barbecue, it must be constructed and marked as meeting the specifications of:

- Canada: Transport Canada.

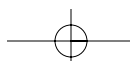

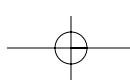
**The Cylinder must also be equipped with:**

- A shut-off valve with a correct cylinder valve outlet as specified in current standards.
 - Canada: CAN/CGA 1.6g-M97 Outdoor Gas Grilles.
 - a) A safety relief valve with direct connection to the vapour space of the cylinder.
 - b) A collar to protect the tank shut-off valve.
 - c) A device for vapour withdrawal.
 - d) A ring on the bottom to secure the tank to its support assembly.
- Always turn off the cylinder valve completely when the barbecue is not in use.
 - Always handle the tank valve with utmost care.
 - Never connect an unregulated L.P. gas cylinder to the barbecue.
 - Always keep the cylinder, in use, securely fastened in an upright position.
 - Never store a spare cylinder, empty or full, near or under the barbecue when in operation.
 - Never expose the cylinders to direct sunlight or excessive heat.
 - Never insert any kind of object into the valve outlet as this may damage the backcheck; a backcheck that is damaged can leak, and a leaking propane cylinder can result in fires or explosions, property damage, severe injuries or death.

**TRANSPORTATION
AND STORAGE
OF CYLINDER**

The propane cylinder is totally safe when handled properly, but if misused, the result could be an explosion or fire resulting in serious personal injury and/or property damage.

To Avoid Unnecessary Risks

- Always recap the cylinder with the cap provided when not connected to the barbecue.
- **Do not** store the cylinder in any enclosed area such as a garage, and make sure the storage area has lots of ventilation.
- **Do not** store the cylinder near any appliances, or in any areas that may become hot, such as the trunk of a vehicle.
- Make sure the cylinder is out of reach of children.
- When transporting or storing the cylinder, make sure it is in an upright position and not on its side.
- **Do not** smoke around the cylinder, especially when transporting it in a vehicle.

**FILLING
THE CYLINDER**

The cylinder must be filled prior to use and must have the air purged. For safety, follow these instructions when having your cylinder filled:

- Have only your local qualified LP gas dealer fill or repair a cylinder.
- **Do not** overfill the cylinder beyond the safe 80% fill level.
- Make sure the dealer tests and checks the cylinder for leaks after filling.

WARNING

**If the above instructions are not completely adhered to,
it could cause a fire / explosion, resulting in death or serious injury,
or property damage.**

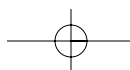

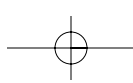

HOSE AND REGULATOR

Propane Gas Models: Your barbecue is designed to operate on L.P. (Propane) gas at a pressure of 2.74 Kpa (11" water column). A regulator preset to this pressure is supplied with the barbecue and must be used.

This regulator is equipped with the Type-1 quick-closing connecting system, which incorporates these safety features:

- Will not allow gas to flow until a positive seal has been made.
- Has a thermal component that will automatically shut off the flow of gas between 115-150°C (240-300°F).
- Has a flow limiting feature, which will restrict the flow of gas to 10 cubic feet/hour.

Should the large, black thermal-sensitive coupling nut be exposed to any extreme temperatures above 115°C it will soften and allow the regulator probe to disengage from the valve, and will shut off the gas. Should this occur, **do not** try to reconnect the nut; instead replace the whole regulator assembly with a new one (see the attached parts listing for details). The regulator probe also contains a flow-sensitive feature, which limits the flow of gas to 10 cubic feet/hour, in the event of a regulator malfunction or hose leak. If the flow control feature is activated, the cause of this excessive gas flow should be investigated and corrected before using the barbecue again.

Note: Improperly lighting the barbecue can activate the flow control feature, resulting in lower heat output. If this occurs, the re-flow feature must be reset by turning all the burner controls and the cylinder valve off. Wait at least 30 seconds before slowly turning on the cylinder valve, and then after another 5 seconds turn the burner valve on and light the barbecue.

- Never connect this barbecue to an unregulated propane gas supply, or to another kind of gas. **Do not** alter or change the hose or regulator in any way.
- Visually inspect the whole hose assembly before each use for evidence of wear or damage such as cracks, burns, or cuts. If any damage is found, replace the assembly before using the barbecue. Use only the recommended replacement hose.
- To avoid possible damage to the hose, **do not** allow any grease or other hot materials to fall on the hose, and make sure the hose does not contact any hot surfaces of the barbecue.
- The connection fitting must be protected when it's disconnected from the cylinder. **Do not** allow the fitting to bump or drag on the ground as nicks and scratches could help create a leak when connecting back to the cylinder.
- It is important to do the "Leak Test" procedure every time a cylinder is refilled or any of the components are changed, and especially at the beginning of a new season.

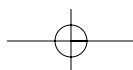

LEAK TESTING

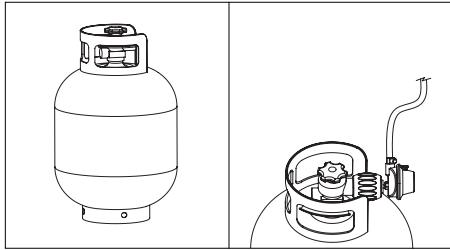

Drawing B

Drawing C

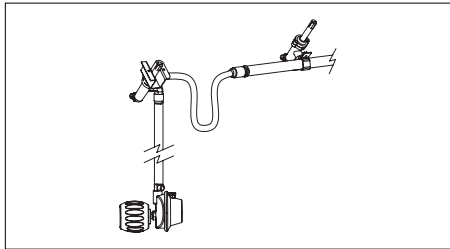

Drawing D

Perform a "Leak Test"

- Before lighting your barbecue for the first time.
- Every time the cylinder is refilled, or any component is replaced.
- At least once every year, preferably at the start of the season.

The "Leak Test" must be done outdoors, away from heat, open flames and flammable liquids.

Do not smoke while performing the test. Use only a mixture of 50/50 liquid soap and water for leak testing. Never use a match or open flame.

The Following Must Be Checked

- The tank valve including the threads into the tank (Drawing C).
- All tank welds (Drawing B).
- Regulator fittings and tank connections (Drawing C).
- All hose connections (Drawing D).
- **With a newly filled and tested propane tank attached to the barbecue and all the barbecue controls turned "OFF", slowly open the cylinder valve one full turn.**
- **Using a brush and soap, soak all the connections and components listed above and shown in drawings B, C, D.**
- **Look carefully for bubbles forming, which is an indication of leaking gas.**
- **Tighten the connections at the bubbled areas until re-testing shows no indication of any leaks (shut off cylinder while correcting any leaks).**
- Shut off the cylinder valve and ensure all control valves are off.
- **Do not** use the barbecue if any leaks cannot be stopped. Turn off the gas cylinder valve, remove the gas cylinder and seek assistance from a qualified gas appliance service mechanic or gas dealer.

PRIOR TO USING

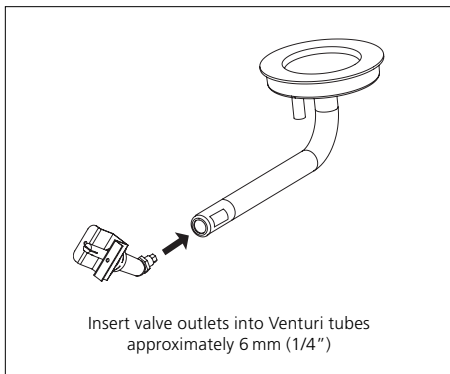

Drawing E

Do not use your barbecue until you have carefully read and fully understand all the information in this manual. Please ensure the following:

- Your barbecue is properly assembled.
- There are no leaks in the system (see "Leak Test").
- The burner is properly assembled, with the Venturi tubes seated over the valve outlets (Drawing E) and that there is nothing blocking the Venturi tubes (Drawing F).
- Ensure that all power cords and/or gas supply hoses will not touch or be near surfaces that will get hot.
- The barbecue is in a safe location (see Installation).

Ensure that the valve outlets (orifices) are assembled into the Venturi tubes approximately 6 mm (1/4") and that the valve outlets and Venturi tubes are approximately parallel to the bottom of the lower body.

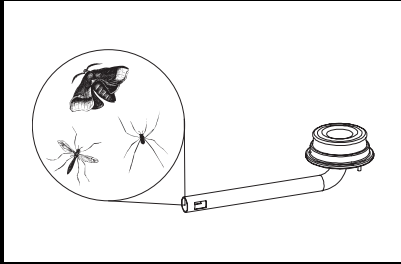
WARNING**Natural Hazards
Insects and Spiders**

Drawing F

During shipment or storage, it's possible that small insects like spiders could find their way into the Venturi tubes and nest or make webs. This could block the flow of gas through the Venturi tube causing a smoky yellowish flame, or prevent a burner from lighting. It could even cause the gas to burn outside the Venturi tube, which could seriously damage your barbecue. If these occur, turn off the gas flow and wait for the barbecue to cool down. When the barbecue has cooled, remove the burner and clean out the Venturi tubes with a brush or pipe cleaner. Replace the burner and ensure that the Venturi tubes are seated over the orifice located on the gas valves. Cleaning the Venturi tubes should be conducted periodically, especially at the start of the season.

Note: Damage resulting from blocked Venturi tubes is not covered under the warranty.

Orifice Size: The orifice, in conjunction with the control valve, acts to regulate and restrict the amount of gas delivered to the burner. The hole size in the orifice varies by the gas supply pressure and by the BTU rating of the burner. Grills equipped for LP gas operate at a much higher gas pressure and therefore have a smaller size orifice.

Hose and Regulator Inspection

Adjustment: The regulator is factory set at a specified outlet pressure of 11" of water column and is generally factory sealed and not adjustable. Do not try to adjust. The regulator can be checked by measuring the pressure with a manometer.

Vent Hole: There is a vent hole on top of the regulator. Check that it is clear of dirt and debris. If the hole is plugged, erratic and dangerous burning may result.

O-ring Seal: Before attaching the regulator to the cylinder, inspect the rubber O-ring on the P.O.L. fitting. Do not operate the grill if the O-ring is damaged or missing. Seal damage is common and we recommend replacement of the seal when the burner is replaced or when the seal is damaged. Cracks, splits or distortion will allow gas to escape. Additionally, the seal should be soft, pliable, and protrude slightly from the brass P.O.L. valve.

Chew Marks: The hose should be kept clean of grease and food drippings which attract squirrels and other animals. The animals will often eat the drippings on the hose and chew into the hose lining trying to get the last taste. Try cleaning the hose with an ammonia cleaner solution to minimize the attraction.

Test For Leaks

1. Mix a 50/50 solution of liquid dish soap and water.
2. Connect the LP cylinder.
3. Make sure the control valves are OFF.
4. Brush the soap solution over the P.O.L. valve and all piping and hose connections.
5. Turn on the cylinder valve and listen for leaks, and look carefully for soap bubbles being formed at the connections which indicates leaks.



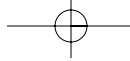

To Reset The Gas Regulator Safety Device

1. Close the LP (propane) tank valve.
2. Turn all burner control knobs to the OFF position.
3. Disconnect the regulator from the LP tank.
4. Open the grill lid.
5. Open all of the control knobs to the high position.
6. Wait 2 minutes.
7. Close all of the control knobs.
8. Re-connect the regulator to the LP tank. Test for leaks.
9. With lid open, turn the left burner control knob to the "HIGH" position and then ignite the grill by turning Rotary ignitor clockwise.
10. Once lit, close the grill lid.
11. Wait for 10 to 15 minutes for the Barbecue to preheat.

ATTENTION: Proper start up and shut down procedures should be Followed to avoid regulator safety device activation.

WARNING

If the heat output is too low, the flow control feature may have been activated by a gas leak. If so, turn off the burner valve and cylinder valve, and perform the "Leak Test". If there aren't any leaks, re-light the burner.

LIGHTING THE GRILL

Make Sure you have followed all the safety checks, procedures and instructions indicated in the previous section, before attempting to light the grill.

Lighting The Main Burners

1. Always open the hood completely and always inspect the grill and burners to confirm that all components are properly positioned before lighting the main burners.

WARNING

Never stand with your head directly over the Barbecue when preparing to light the main burners, to prevent possible bodily injury.

2. Always confirm that all of the burner control knobs are in the OFF position before opening the gas supply.
3. Slowly turn on the propane gas supply valve at the tank 1-2 turns.
4. Wait approximately 5 seconds before turning the selected burner control to the HIGH position by pushing down on the knob and turning it counter-clockwise. This procedure allows pressure to stabilize, and prevents the flow limiting feature from being activated.
5. Immediately turn the Rotary Ignitor knob clockwise. As you turn the ignitor you will hear a click as the Piezo module generates an ignition spark to the burner. Rotate the ignitor knob until the burner lights. The selected burner should light within 5 seconds. Light the burners sequentially from left to right.

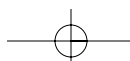

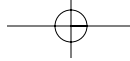

WARNING

IF THE SELECTED BURNER DOES NOT LIGHT, immediately turn the burner control knob and cylinder valve to the OFF position, to prevent gas buildup. Wait five minutes for the gas to clear and then repeat the preceding starting procedure. IF the burner will not light when using the Ignitor, follow the match lighting instructions.

6. Confirm that the burner is properly lit. If the flame pattern is other than normal, consult the Troubleshooting Guide for corrective action.
7. Always preheat the Barbecue before starting to cook. Light all burners and adjust them to the HIGH position for 5-10 minutes. Before placing any food on the Barbecue, clean the cooking grids with a Porcelain cleaning brush.
8. Adjust the controls to a medium setting for most cooking requirements. A light coating of cooking oil on the cooking grids, before heating the grill, will prevent foods from sticking to the grill.

Turning The Burners Off

1. Always turn the burner control knobs to the off position when cooking has been completed.
2. Promptly turn OFF the gas supply valve at the propane cylinder.
3. Close the hood of the grill.

Match Lighting The Main Burners

1. Always open the hood completely and inspect the grill and burners to confirm that all components are properly positioned, before lighting the main burners.

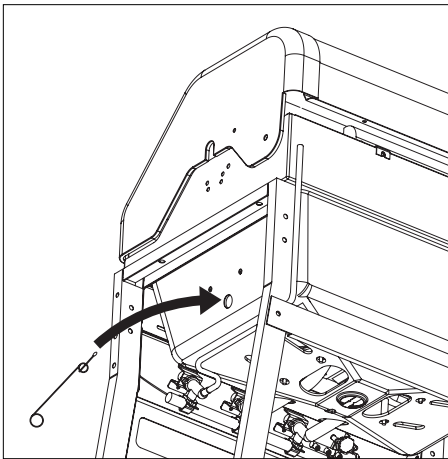

Drawing G

WARNING

Never stand with your head directly over the Barbecue when preparing to light the main burners, to prevent possible bodily injury.

2. Always confirm that all of the burner control knobs are in the OFF position before opening the gas supply.
3. Always turn on the propane gas supply valve at the tank (1-2 turns).
4. Insert a lit match or a butane lighter into the match lighting hole located on the lower left hand side of the firebox (Drawing G).
5. Turn the left burner control knob to the HIGH position by pushing on the knob and turning it counter-clockwise.

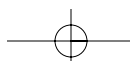

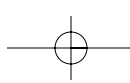

GENERAL

GRILLING TIPS

Before preheating the grill make sure that the appliance is safe, and clean.

Check your propane level before cooking so you don't run out of fuel before finishing.

- Preheat the grill, set all bottom burners at high heat with the hood closed for about 10 minutes. To allow for quick burnoff place aluminum foil over entire cooking surface and with grill set to high allow grill to stand with lid closed for 5 minutes. All grease will liquify for easy removal.
- For even cooking and to prevent flare-ups or burning, move food around on the cooking grids.
- Cook with the lid down and on medium heat to ensure even cooking. Food cooked in a covered grill cooks faster, easier, and more efficiently.
- Trim excess fat from meats to avoid flare-ups. Less fat makes clean up easier and is also healthier.
- It is not safe food practice to bring meat to room temperature before cooking. All meat must be refrigerated.
- Use long handled tongs for turning steaks or roasts and spatulas for turning burgers and fish. Do not use a fork for turning as it will pierce the meat allowing flavourful juices to escape.
- Determine the degree of cooking of steaks by cutting a small slit near the bone and checking the colour. For boneless cuts, make a slit near the centre. For thicker steaks, use a quick recovery meat thermometer to accurately gauge the internal temperature. For large pieces of meat and poultry insert thermometer into the centre of the largest muscle of meat or in the inner thigh or breast of poultry. Charring meat, poultry, or fish is not recommended.
- If you turn the controls to high and close the hood for a few minutes your grill will virtually self clean. Brush off loose residue.
- When grilling steaks, remember to keep in mind one guiding principle: moisture must be retained in the steaks for tender, juicy and flavourful meat. Therefore:
 1. Salt steaks after cooking to prevent loss of moisture.
 2. Turn steaks when bubbles appear on the surface. Each time bubbles appear, turn steak over so that the moisture goes back into the steak.
 3. Steak should only require turning once or twice.
 4. Barbecue sauces are best applied towards the end of cooking to prevent burning.

To prevent food from sticking, you can brush or rub cooking oil on to the cooking grids. If using vegetable cooking spray use it only before lighting the burners.

CAUTION

Never spray into the grills while burners are on.

WARNING

Do not leave your barbecue unattended, and watch out for children around the barbecue. Make sure the barbecue is functioning safely at all times. Do not move the barbecue while cooking.

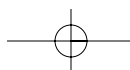

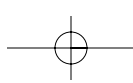

BARBEQUE COOKING METHODS

Your barbecue is more than just a place to grill your burgers and hotdogs – the possibilities are endless. But, before you start experimenting, here are some frequently used terms that will help:

- **Direct Cooking** is also known as grilling. This is the most popular cooking method and involves cooking food directly over the flame, such as searing a steak. Other good candidates for this cooking method are thin cuts of meat, vegetables, kabobs and fillets.
- **Indirect Cooking** means the food is cooked away from the direct flame by placing it on the opposite side of the lit burner and allowing the heat to tumble within the closed confines of the closed barbecue, very similar to a convection oven. Much like your oven, you can roast and even bake, provided your barbecue lid is closed.

Flare Ups

Flare-ups sometimes occur when food drippings fall onto the hot flame tamers or burners and ignite. Some flaring is normal and desirable, as it helps impart the unique flavors associated with grilled foods. Controlling the intensity of the flare-ups is also desirable, however, in order to avoid burned or unevenly cooked foods and to prevent the possibility of an accidental fire

ALWAYS MONITOR THE GRILL CAREFULLY WHILE COOKING AND TURN THE FLAME LEVEL DOWN TO LOW OR OFF IF FLARE-UPS INTENSIFY.

To keep flare-ups to the desired level, do the following:

1. Trim fat from meats before grilling
2. Cook chicken and pork on lower settings
3. Ensure that the bottom of the firebox is cleaned regularly to eliminate extreme grease build up.
4. Always cook with the lid down, and cook at the lowest most efficient heat setting.

Flare-ups can increase the temperature of the grill and add to the buildup of grease, increasing the risk of a grease fire.

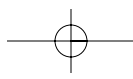
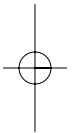
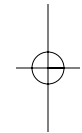

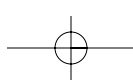

COOKING TIME CHART

| Types of Food | Weight/Thickness | Cooking Temperatures | Cooking Time |
|--|------------------|---|--|
| Beef | | | |
| Burgers | 1" | 400-450°F | Rare: 4-7min Medium: 7-10 min Well Done: 10-12 min |
| Roasts | | | |
| Blade, Sirloin Tip | | 350°F | Rare: 18-20min Medium: 20-25 min Well Done: 25-30 min |
| Steaks | | | |
| Porterhouse, Rib Ribeye, Sirloin, T-Bone | 1" | Maximum: (To sear) 400-450°F (To Finish) | Rare: 4-7min Medium: 7-10 min Well Done: 10-12 min |
| Filet Mignon | 2" | Maximum: (To sear) 400-450°F (To Finish) | Rare: 15-17 min Medium: 17-19 min Well Done: 19-22 min |
| Poultry | | | |
| Chicken, Parts | | 325-350°F | 30-45 min |
| Chicken, Whole | 3-4 lb | 325-350°F | 20 min/lb |
| Chicken Breasts, Boneless | 1-2 lb | 325-350°F | 12-15 min |
| Cornish Hen | 1-1 1/2 lb | 325-350°F | 45-60 min |
| Duck | 4-5 lb | 325-350°F | 18-20 min/lb |
| Turkey | 13-25 lb | 325-350°F | 20 min/lb |
| Fish | | | |
| Fillet | 1-1 1/2" | 400-450°F | 10-15 min |
| Steaks | 1-2 lb | 325-350°F | 20-30 min |
| Whole Fish | 2-4 lbs | 325-350°F | 30-50 min |
| Seafood | | | |
| Lobster | 1 1/2-2 lb | 400-450°F | 15 min |
| Shrimp Large | Large | 325-350°F | 5-6 min |
| Pork | | | |
| Chops | 1" | 400-450°F | 25-30 min |
| Ham | | | |
| Steak | 1" | 400-450°F | 12-15 min |
| Whole Ham | 12-14 lb bone in | 325-350°F | Medium: 20-25 min/lb Well Done: 25-30 min/lb |
| | 4-5 lb Boneless | 325-350°F | 50-60 min |
| Ribs | | | |
| Back, Side | 5-6 lbs | 325-350°F | Medium: 25-27 min/lb Well Done: 27-30 min/lb |

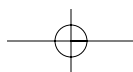

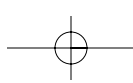

COOKING TIME CHART

| Types of Food | Weight/Thickness | Cooking Temperatures | Cooking Time |
|----------------------|------------------|----------------------|---|
| Roasts | | | |
| Butt, Loin, Shoulder | 3-5 lb | 325-350°F | 1-1 1/2 hrs |
| Tenderloin | | 375-400°F | Medium: 30-35 min/lb Well Done: 35-40 min/lb |
| Sausage | | 325-350°F | 12-20 min |
| Lamb Chops | | | |
| Loin, Rib, Shoulder | 1" | 400-450°F | Rare: 7-9min Medium: 10-13 min Well Done: 14-17 min |
| Roast | | | |
| Crown Roast | 2-4 lb | 325-350°F | 40-45 min/lb |
| Leg | 5-9 lb | 325-350°F | 30-35 min/lb |

COOKING TIME CHART

| Vegetables | Cooking Temperature | Cooking Time | Comments |
|-----------------|---------------------|--------------|---|
| Asparagus | 325-350°F | 6-8 min | Cut off ends of stems. Lay across the grill. |
| Beans | 325-350°F | 30-35 min | Wrap in foil with butter or margarine. Turn over once. |
| Carrots | 325-350°F | 20-30 min | Cook directly on the grill. |
| Corn on the Cob | 325-350°F | 25-35 min | Soak in cold water for 15 minutes. Cook with husk on. |
| Eggplant | 325-350°F | 6-8 min/side | Cut into slices and coat with olive oil. |
| Mushrooms | 325-350°F | 6-8 min | Cook Directly on the grill. |
| Onions | 325-350°F | 40-45 min | Wrap in foil. Turn over once. |
| Peppers | 400-450°F | 15-20 min | Remove charred skin before eating. |
| Potatoes | 325-350°F | 50-60 min | Wrap in foil. Turn over once. |
| Roasted Garlic | 325-350°F | 30-40 min | Cut off top of bud and lightly coat with olive oil. Wrap in foil. |
| Tomatoes | 325-350°F | 5-7 min | Cut in half and coat with olive oil. |
| Zucchini | 325-350°F | 6-8 min/side | Cut into slices and coat with olive oil. |

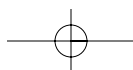

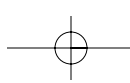

CLEANING AND MAINTENANCE

To get many years of service out of your barbecue, perform the following procedures at least once a year, especially at the start of a new season. Purchase a barbecue cover to protect your investment.

Cooking Grate: Apply a light coating of cooking oil to the grating to prevent food from sticking. After each use, and after the barbecue has cooled down, scrub the grating with a non-abrasive brush. Alternatively, you can wash the grate with a mild detergent or baking soda. **Do not** use a commercial oven cleaner.

Burner and Venturi Tube: At a minimum of twice a year, it is important to remove the burner and Venturi tube and clean them, making sure that all dirt and rust is removed. Use a wire to clean out the hole in the Venturi tube. Make sure the bottom housing is clean and all holes are clear. If the burner has been damaged or has rusted, replace it as soon as possible. If the burner is in good shape, reinstall it in the correct position. Also ensure that the Venturi tube is centred over the valve outlet.

STORAGE

When the outdoor cooking season is over and you're going to store the unit for the winter, perform the following maintenance:

- After removing and cleaning the burner and grill (lightly oil the grill after cleaning) wrap them in paper and store indoors.
- The barbecue, after being covered, can be stored outdoors.
- **Do not** store the L.P. cylinder in an enclosed area.
- Remove igniter battery to avoid corrosion, if storing unit away in the winter, or for a prolonged period.

When the barbecue is not in use, the gas must be turned off at the cylinder valve. The barbecue and cylinder need to be stored outdoors, in a well-ventilated area. **Do not** store the barbecue in a garage or near heat. If there is a need for the barbecue to be stored indoors, remove the cylinder. Continue to store the cylinder outside in the well-ventilated area and make sure the cylinder's safety cap is firmly threaded on the valve.

ATTENTION: When moving your Barbecue please ensure that it is supported from the firebox on both sides, and NOT by the side shelves. Ensure that castors are unlocked before moving. DO not roll Barbecue on uneven surfaces as it could damage castors, which could lead to damaging other parts. Trileaf Distribution is not liable for any damage sustained during removal or storage of this Barbecue.

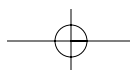

TROUBLESHOOTING GUIDE

| Problem | Possible Causes | Corrective Action |
|---|---|---|
| Burner will not light (match or igniter) | <ul style="list-style-type: none"> Blocked Venturi tubes | <ul style="list-style-type: none"> Clean out blockage |
| Burners not hot enough | <ul style="list-style-type: none"> Cylinder or gas supply valve turned off | <ul style="list-style-type: none"> Open cylinder or gas supply valve |
| | <ul style="list-style-type: none"> Venturi tubes not properly sealed over orifices | <ul style="list-style-type: none"> Ensure proper Venturi assembly |
| | <ul style="list-style-type: none"> Burner ports blocked | <ul style="list-style-type: none"> Clean/replace burner |
| | <ul style="list-style-type: none"> Low or out of propane | <ul style="list-style-type: none"> Refill cylinder |
| | <ul style="list-style-type: none"> Regulator safety device must be reset | <ul style="list-style-type: none"> Follow How to Reset the Gas Regulator Safety Device (page 5) |
| | <ul style="list-style-type: none"> Regulator not fully tightened into cylinder | <ul style="list-style-type: none"> Tighten regulator fully (hand tighten) onto cylinder Straighten fuel hose |
| Flames are smoky and yellow | <ul style="list-style-type: none"> Partially blocked Venturi tubes | <ul style="list-style-type: none"> Clean out blockage |
| | <ul style="list-style-type: none"> Excess cooking salts on burner | <ul style="list-style-type: none"> Clean burner |
| | <ul style="list-style-type: none"> Air shutter closed (side and rear rotisserie burner only) | <ul style="list-style-type: none"> Open air shutter |
| Burner lights with match but not with igniter | <ul style="list-style-type: none"> Loose wire connection | <ul style="list-style-type: none"> Check all connections are tight |
| | <ul style="list-style-type: none"> Broken electrode Poor ground | <ul style="list-style-type: none"> Ensure collector box, burner and igniter are assembled properly |
| | <ul style="list-style-type: none"> Faulty igniter | <ul style="list-style-type: none"> Replace igniter |
| Flame blows out/down through base | <ul style="list-style-type: none"> High wind conditions | <ul style="list-style-type: none"> Relocate barbecue with the back towards wind |
| | <ul style="list-style-type: none"> Propane low | <ul style="list-style-type: none"> Refill cylinder |
| Too much heat/excessive flare-up | <ul style="list-style-type: none"> Excessive fat in meat | <ul style="list-style-type: none"> Trim meat, turn down burner controls and/or fuel supply |
| | <ul style="list-style-type: none"> Grease drain plugged | <ul style="list-style-type: none"> Clean casting base and burner |
| | <ul style="list-style-type: none"> Cooking system not positioned correctly | <ul style="list-style-type: none"> Position cooking system correctly |
| Flames under heat control console | <ul style="list-style-type: none"> Blocked Venturi tubes | <ul style="list-style-type: none"> Immediately shut off gas at source, allow grill to cool and clean out Venturi tubes |
| Regulator humming | <ul style="list-style-type: none"> This is not a defect or a hazard | <ul style="list-style-type: none"> Temporary condition caused by high outside temperatures and a full propane cylinder |
| Incomplete flame | <ul style="list-style-type: none"> Plugged, rusted or leaking burner | <ul style="list-style-type: none"> Clean/replace burner |
| Warming rack will not fit | <ul style="list-style-type: none"> Legs are angled too narrowly, or widely | <ul style="list-style-type: none"> The warming rack legs are adjustable Bend to fit into the warming rack holes |

For more troubleshooting support or parts ordering, please call toll free **1-877-707-5463**.

**PARTS LISTING FOR
85-1261-0 (PROPANE)**

| Item No. | Quantity | Specification | Part No. |
|-----------------|-----------------|-----------------------|-----------------|
| A | 1 | Top Lid Assembly | |
| AA | 1 | Top Lid Weldment | G301-1400-01 |
| AB | 1 | Handle F/ Top Lid | G301-0042-01 |
| AC | 1 | Thermometer | G401-0005-01 |
| AD | 2 | Wing Nut | 33300-13000-01 |
| AE | 2 | Screw for Top Lid | G301-0003-01 |
| B | 1 | Burner Box Assembly | |
| BA | 1 | Burner Box Weldment | G301-1600-01 |
| BB | 2 | Cooking Grate | G301-0043-01 |
| BC | 1 | Flame Tamer | G301-0049-01 |
| BD | 1 | Main Burner | G301-4100-01 |
| BE | 1 | Grease Shield | G301-0008-01 |
| BF | 1 | Warming Rack | G301-0004-01 |
| BG | 1 | Heat Shield | G301-0048-01 |
| BH | 1 | Wind Shield | G301-0051-01 |
| CA | 1 | Control Panel | G301-1500-01 |
| CB | 1 | Electrode Assembly | G301-0010-01 |
| CC | 2 | Control Knob Assembly | G301-0045-01 |
| CD | 1 | Ignitor Knob | G301-0011-01 |
| CE | 1 | Manifold Assembly | G301-1800-01 |
| CG | 1 | Regulator | G402-0069-01 |
| CH | 1 | Upper Rail | G301-0053-01 |
| DA | 1 | Cart Side Assy (L) | G301-1900-01 |
| DB | 1 | Cart Side Assy (R) | G301-0800-01 |
| DC | 1 | Front Sheet | G301-0046-01 |
| DD | 2 | End Cap, Cart Legs | G301-0054-01 |
| DE | 1 | Rear Brace | G301-0031-01 |
| DF | 1 | Side Brace | G301-0030-01 |
| DG | 1 | Gas Tank Holder | G206-0028-01 |
| DH | 2 | Wheel | G401-0058-01 |
| DI | 2 | Wheel Axle | G301-0034-01 |
| DJ | 2 | Wheel Cap | G303-0020-01 |
| DK | 2 | Washer | G301-0028-01 |
| DL | 1 | Bottom Grate | G301-0036-01 |
| DM | 1 | Grease Cup | G401-0066-01 |
| DN | 1 | Hook, Grease Cup | G401-0067-01 |
| EA | 2 | Side Shelf Assembly | G303-8000-01 |

85-1261-0 (PROPANE)

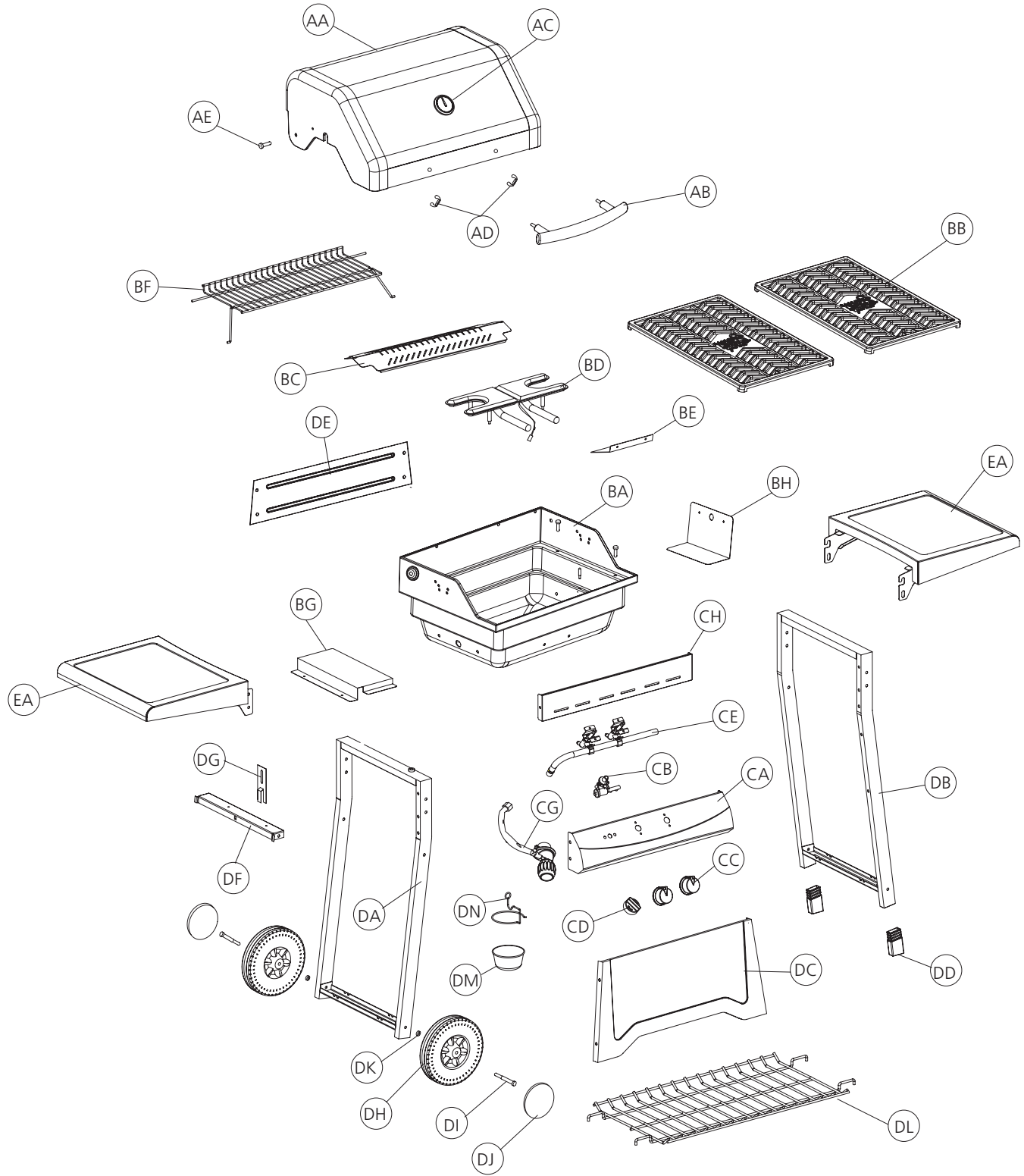

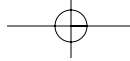

**ASSEMBLY
INSTRUCTIONS**

Tools Needed for Assembly

- #2 ⊕ screwdriver
- 1/4" ⊖ screwdriver
- Adjustable wrench
- Pliers
- Rubber mallet

Before assembling the barbecue, read these instructions carefully.
Assemble the barbecue on a flat, clean surface.

NOTES: DO NOT FULLY TIGHTEN ALL THE NUTS DURING THIS INITIAL STAGE.

Caution: Sheet metal can cause injury. Wear gloves when installing the grill.
Use care when assembling.

You may have extra hardware after assembly is complete.

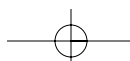
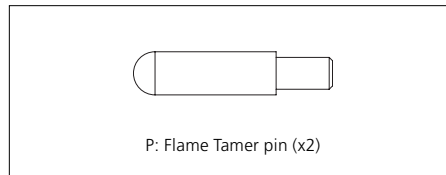
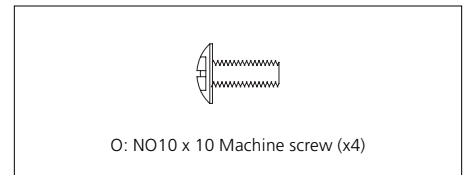
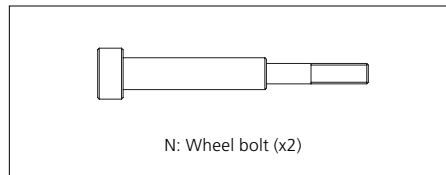
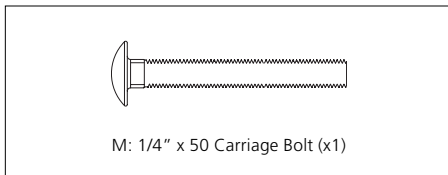
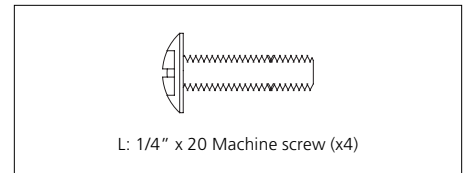
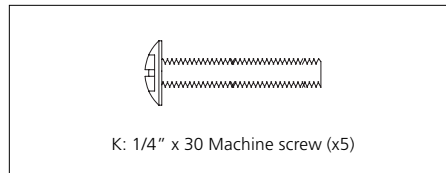
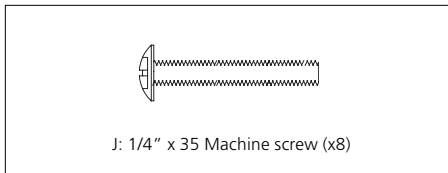
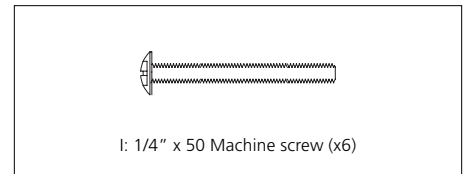
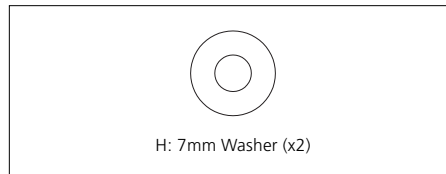
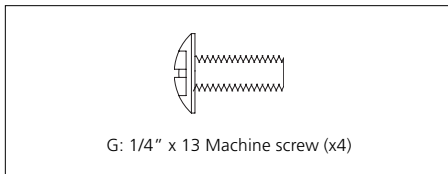
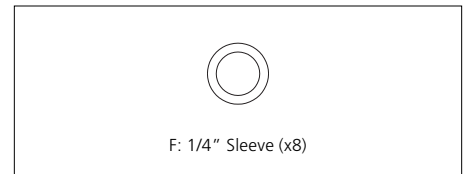
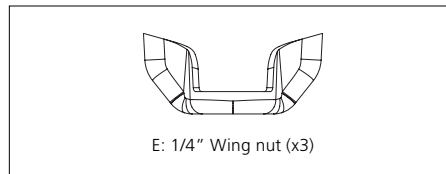
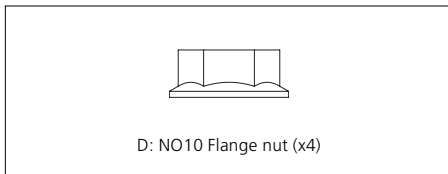
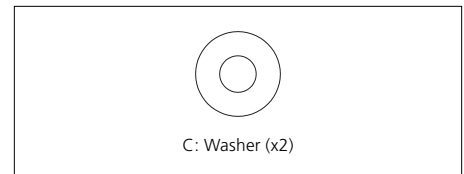
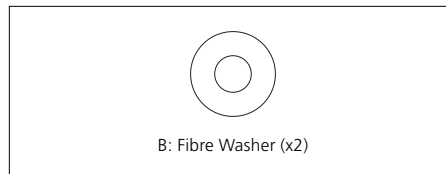
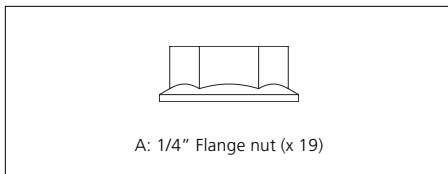

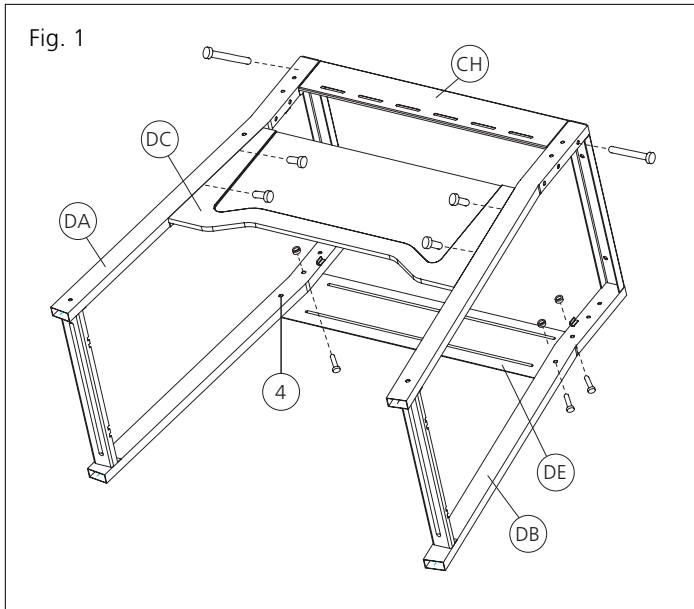

1

After removing the unit from carton please make sure that all hardware is present. Before starting to assemble the unit, read these instructions carefully.

Assemble the upper panel (CH) to the left (DA) and right legs (DB) with I (x2). Assemble the front panel (DC) to both cart legs with G (x4). Assemble the back panel (DE) to both cart legs with A & K (x3).

Note: Leave the 4th (4) hole of the back panel in Fig.1 for assembly later.

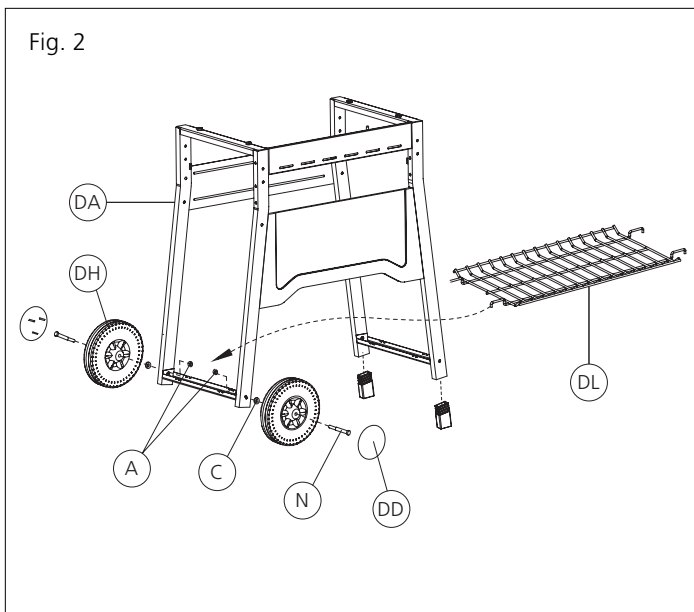

2

Attach the wheels (DH) to the left cart leg (DA) with N, C, & A (x2) in the order as shown in Fig.2. Assemble the end cap (DD x2) to the right cart leg. Place the bottom grate (DL) accordingly (Fig.2).

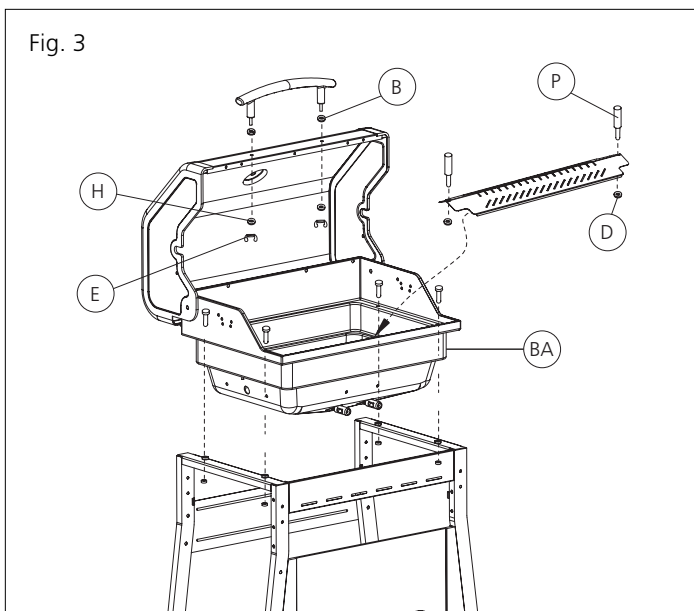

3

Assemble the burner box (BA) to the cart assembly with hardware L & A X 4. Place the flame tamer (BC) in the burner box with P & D (x2). Attach the handle (AB) to the top lid with B, H, and E (x2) (Fig.3).

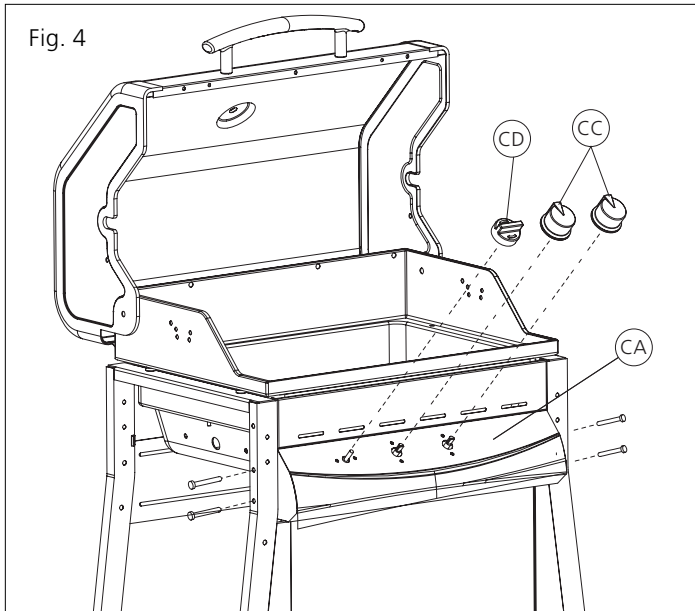

4

Attach the control panel (CA) to the cart assembly with "I" (x4). Insert the control knob (CC) and igniter knob (CD) (Fig.4).

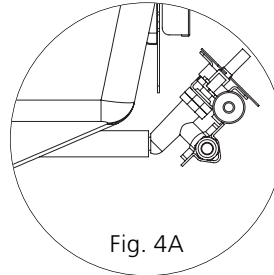

Very Important!

Burner tubes must engage valve openings. Make sure the valves are aligned with the burner tubes (Fig.4A).

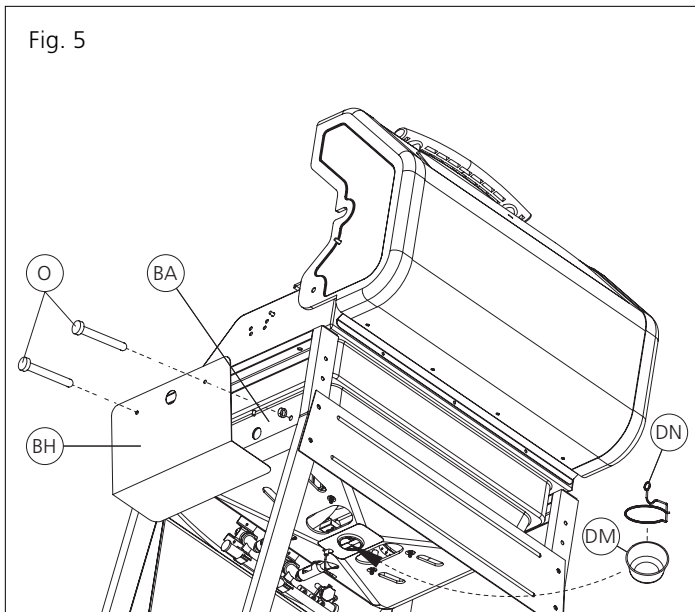

5

Attach the wind shield (BH) to the burner box (BA) with D & O (x2). **Note:** Windsheild nuts (D) must be attached to bolts (O) inside the firebox. Hang the grease cup (DM) with a grease cup hook (DN). Hook the grease cup under the burner box (Fig.5).

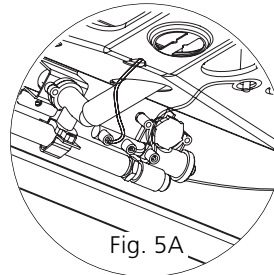

Connect the igniter wires to the electrode (Fig.5A).

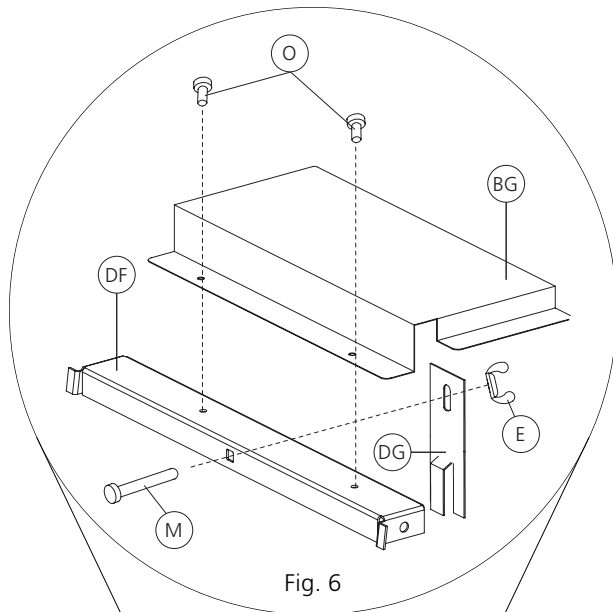

6

Assemble the heat shield (BG) to the side brace (DF) with O (x2). Attach the gas tank holder (DG) to the side brace by with M & E (x1) (Fig.6).

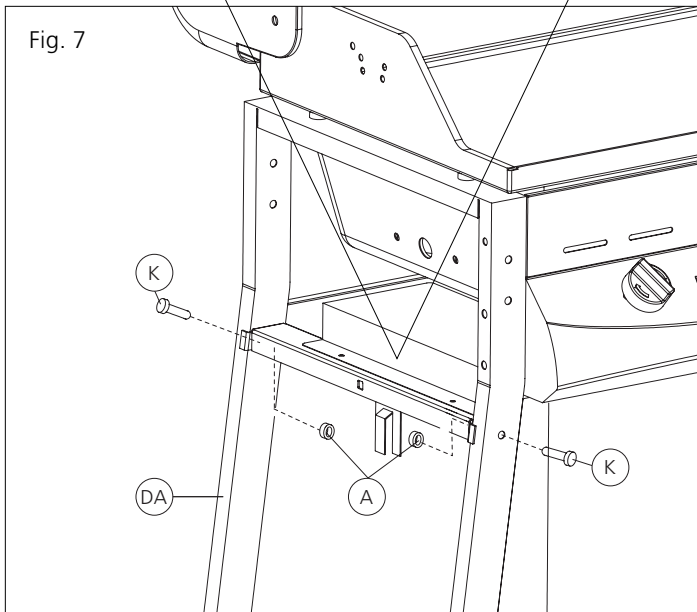

7

Secure the heat shield assembly to the left leg (DA) with A & K (x2) (Fig.7).

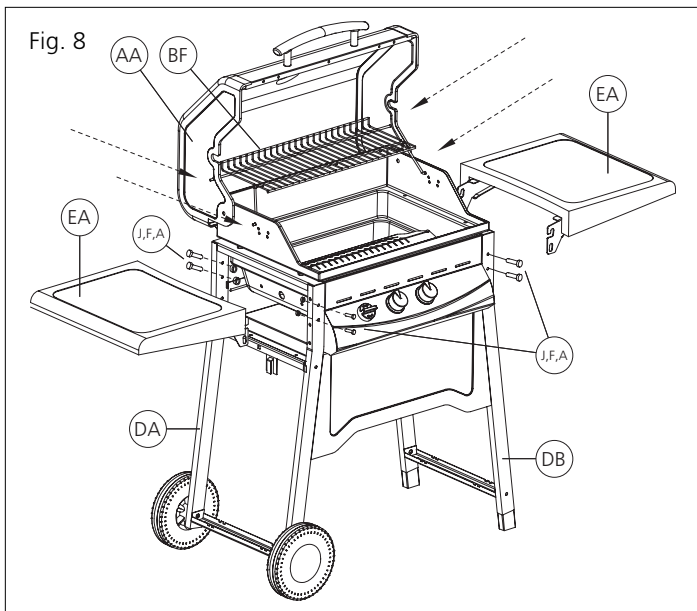

8

Attach the side shelves (EA) to the cart legs (DA) and (DB) with J, F and A (x8). Make sure the sleeves (F) are set between J and A. Attach the warming rack (BF) to the inside of the top lid (AA) by inserting the supporting rods into the pointed holes (Fig.8).

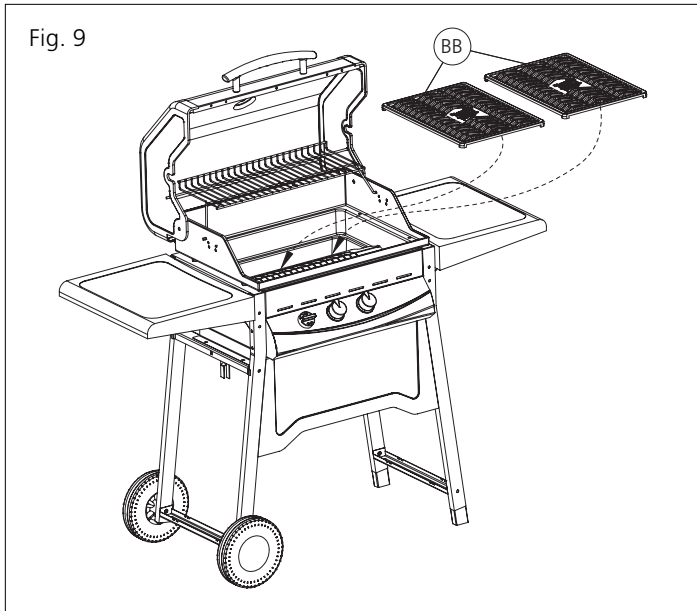

9

Place the cooking grates (BB) into the burner box (Fig.9).

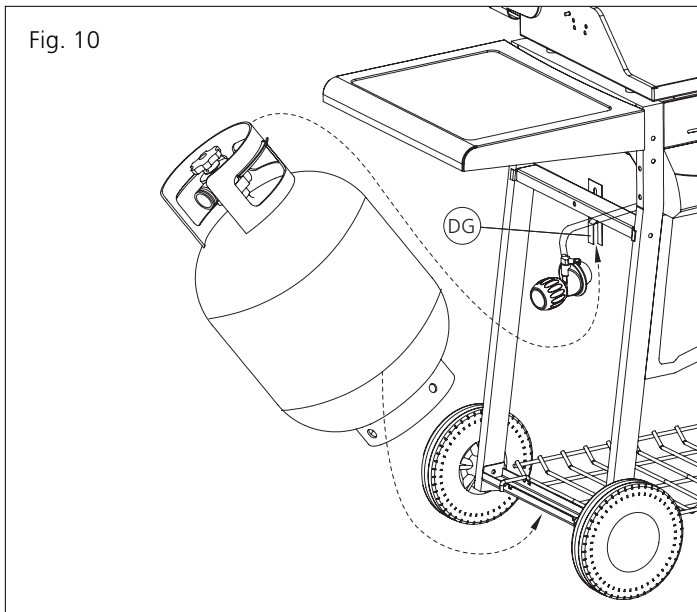

10

Use the gas tank holder (DG) to secure the propane tank to the bottom brace (Fig.10).

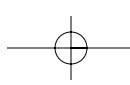

DISTRIBUTOR

Trileaf Distribution Trifeuil
Toronto, Canada
M4S 2B8

